

Features

- 15.6" New Generation Stainless Steel Panel PC
- 12th/13th Gen. Intel Core i3/i5 BGA Type Processor
- True Flat Front Bezel Design and Grade 304 Stainless Steel Enclosure (Grade 316 for Option)
- IP66/IP69K Rated with M12 Connectors
- Support Resistive Touch, Projected Capacitive Touch
- Touch on/off Button on the Side Edge for Hygienic Cleaning
- Support Ergonomic Versatile Mounting: Yoke Mounting / Space-saving VESA 75 x 75mm Mounting

Specifications

System				
CPU	Intel Core i3-1215U Processor, 6C8T, 10M Cache, 1.2GHz (4.4GHz) Intel Core i5-1235U Processor, 10C12T, 10M Cache, 1.3GHz (4.4GHz)			
System Chipset	SoC			
Memory	2 x 260-pin SO-DIMM up to 64GB DDR4 3200MHz			
TPM	TPM 2.0			
IO Port				
USB	1 x M12 8-pin for USB 2.0 with waterproof cover			
Serial / Parallel	1 x M12 8-pin COM1, RS-232/422/485, default RS-232, with waterproof cover			
LAN	1 x M12 8-pin for LAN with waterproof cover			
Others	1 x Touch on/off button at the side			
Power Connector	1 x M12 3-pin for DC power with waterproof cover 1 x Power switch on the rear			
Option	2 x optional blank M12 connector with waterproof cover for selecting two from the following options: 2 x USB 2.0 1 x USB 3.0 1 x LAN 1 x COM			
Storage Space				
M.2	1 x M.2 2280 M-Key (PCIex4)			
Expansion				
Expansion slot	1 x M.2 3402/3052 B-key (PCIe x1, USB3.2 Gen1) for optional LTE/5G module 1 x M.2 2230 E-Key (USB2.0, PCIe x1) for optional Wi-Fi/BT module 1 x Nano-SIM card			
RFID module	RFID module design on the front side (for option)			
Display				
	Standard	High Brightness Optional		
Display Type	15.6" TFT-LCD		15.6" TFT-LCD	
	default	optional	default	optional
Max. Resolution	1366 x 768	1920 x 1080	1366 x 768	1920 x 1080
Max. Color	16.7M	16.7M	16.7M	16.7M
Luminance (cd/m ²)	400	500	1000	1000
View Angle	170(H)/160(V)	178(H)/178(V)	160(H)/160(V)	170(H)/170(V)
Contrast	500:1	1000:1	500:1	1000:1
Backlight Lifetime	50,000 hrs	50,000 hrs	50,000 hrs	50,000 hrs
Touch Screen				
Type	Resistive Touch (for DR model) Projected Capacitive Touch (for DP model)			
Interface	USB			
Light Transmission(%)	Resistive Touch : 80% / Projected Capacitive Touch : 90%			

Dimensions

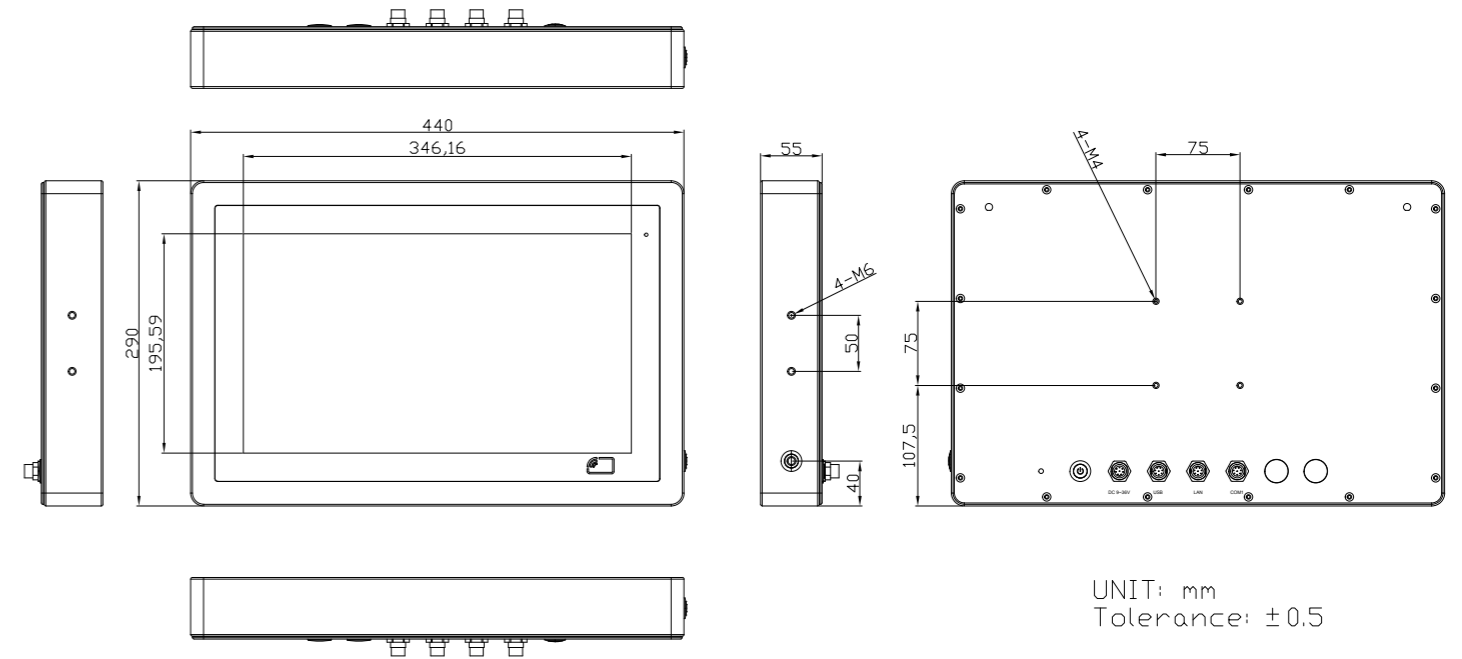

Power	
Power Input	DC 9~36V
Power Consumption	TBD
Mechanical	
Construction	304 Stainless steel chassis(default), 316 Stainless steel chassis(optional)
Mounting	VESA mount 75 x 75, Yoke mount for optional
IP Rating	Total IP66/IP69K
Dimensions	440 x 290 x 55 mm
Net Weight	6.64 kg
Environmental	
Operating Temperature	0~50°C / -20~60°C for option
Storage Temperature	-30~70°C
Humidity	10 to 95% @ 40°C, non-condensing
Certificate	CE/FCC Class A
Operating System Support	
Windows 10, Windows 11	
Accessory	
1 x M12 USB2.0 Y-Cable, L=3M	
Ordering Information	
ViTAM-916DP	15.6" WXGA IP66/IP69K stainless steel panel pc, Intel 12th/13th Gen. Core i Processor, 2 x SO-DIMM DDR4 slots, 128GB TLC SSD, projected capacitive touch, 9~36V DC power input with Adapter
ViTAM-916DR	15.6" WXGA IP66/IP69K stainless steel panel pc, Intel 12th/13th Gen. Core i Processor, 2 x SO-DIMM DDR4 slots, 128GB TLC SSD, 5 wire resistive touch window, 9~36V DC power input with Adapter
ViTAM-916DPH	15.6" WXGA IP66/IP69K stainless steel panel pc, Intel 12th/13th Gen. Core i Processor, 2 x SO-DIMM DDR4 slots, 128GB TLC SSD, projected capacitive touch, 9~36V DC power input with Adapter, 1000 nits
ViTAM-916DRH	15.6" WXGA IP66/IP69K stainless steel panel pc, Intel 12th/13th Gen. Core i Processor, 2 x SO-DIMM DDR4 slots, 128GB TLC SSD, 5 wire resistive touch window, 9~36V DC power input with Adapter, 1000 nits