

TG900AD

8" Intel® Core™ i5-1235U Windows Rugged Tablet Controller



KEY FEATURES

- 8" 1920 x 1200 IPS LED Panel with direct optical bonding
- Intel® Core™ i5-1235U processor
- Sunlight readable with antiglare solution
- Supports WIFI, BT, and optional 4G/5G
- All-weather, dust, and water-resistant design (IP65). MIL-grade drop, Shock and vibration

INTRODUCTION

Winmate's 8-inch Windows rugged tablet controller delivers compact, reliable performance for industrial applications. Featuring a 1920 × 1200 IPS LED panel with direct optical bonding and antiglare technology, it ensures sunlight-readable clarity in outdoor environments. Powered by the Intel® Core™ i5-1235U processor and Windows OS, it offers secure computing with seamless Wi-Fi, Bluetooth, and optional 4G/5G connectivity. Built to IP65 and MIL-STD standards, it endures dust, water, shock, vibration, and drops for all-weather durability.

SPECIFICATIONS

Display

Bonding	Optical Bonding for Sunlight Viewability	Type	Projected Capacitive Multi Touch
Viewability	Anti-Glare touch treatment	Touch Mode	Support Hand / Gloves and Rain Mode
Resolution	1920x1200	Size	8.0 inches
Contrast Ratio	1000:1	Panel Brightness	1000.0 nits
View Angles	85,85,85,85		

System Specification

Processor	Intel® Core™ i5-1235U 3.3GHz(up to 4.40 GHz) Intel Core i3/i7 Processor (Optional)	Memory	8GB DDR5 SDRAM, up to 32GB
Storage	M.2 Gen4 256GB SSD, up To 2TB SSD	Operating System	Windows 10 IoT Enterprise LTSC (64 bit) (Optional) Windows 11 IoT Enterprise LTSC (64 bit) (Optional) Linux Ubuntu 22.04 (Optional)
WLAN	802.11a/b/g/n/ac/ax	BT	5.3
WWAN	4G LTE (Optional) 5G (Optional)	GNSS	GPS/GLONASS

Mechanical

Dimension	259.8 x 166.1 x 44.2 mm	Cooling System	Fan Design
------------------	-------------------------	-----------------------	------------

IO Ports

USB Port	1 x USB 3.0 (Type-A) 1 x USB 3.0 (Type C)	Video	1 x micro HDMI output
Audio	1x Speaker		

Environment

Operating Humidity	10% to 90% RH, non-condensing	Operating Temperature	-20°C to 60°C (AC mode), -10°C to 50°C (Battery mode)
---------------------------	-------------------------------	------------------------------	---

Storage Temperature	-30°C to 70°C (-22°F to 158°F)	Shock	MIL-STD-810H Method 516.8 Procedure I
Vibration	MIL-STD-810H Method 514.8 Procedure I	IP rating	IP65
Certification			
Certification	CE, FCC		
Control			
Button	8 x Buttons		
Power			
Battery	11.4V, typ. 3500 mAh Lilon Removable Battery (3S1P)	Power Rating	19V DC
Adapter	PD Adapter 100W		
Accessory			
Accessory	1 x PD Adapter 100W 1 x Power Cord	Optional Accessory	M12 LAN (10/100 Mbps , Max to 250 Mbps)

DIMENSIONS UNIT:MM

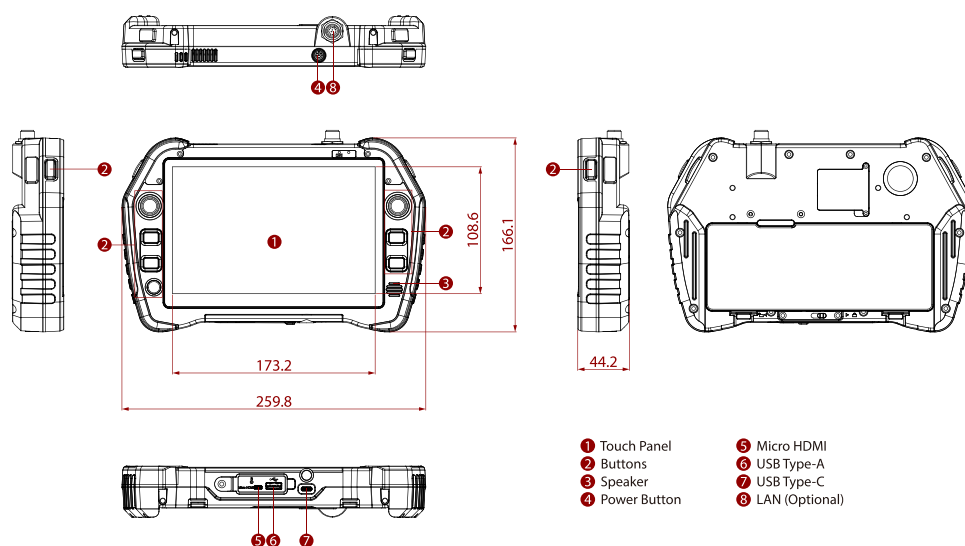

NOTE

1. This is a simplified drawing, and some components are not marked in detail.
2. Please contact our sales representative if you need further product information.
3. All specifications are subject to change without prior notice.
4. The product shown in this datasheet is a standard model. For diagrams that contain customized or optional I/O, please contact the Winmate Sales Team for more information.